

TRIMCLAD®

*Technical
Specifications*

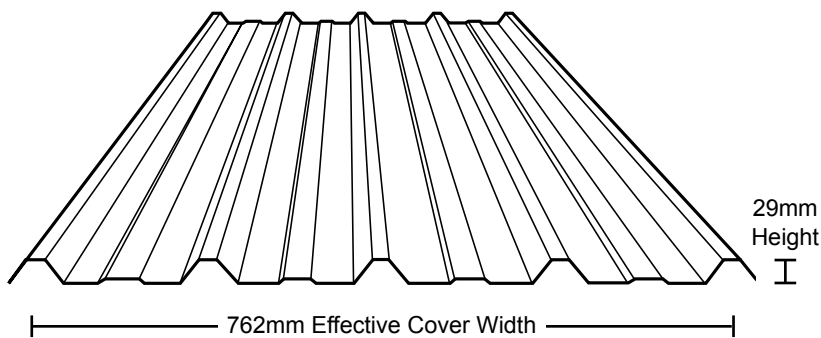



2° Minimum Roof Pitch

Specifications

Referenced Australian Standards

AS 1170.2	SAA Loading Code - Wind Loads
AS 1397	Sheet and Strip Hot-Dipped Zinc-Coated or Aluminium/Zinc Coated
AS 1526	One Part Polysulphide-based Sealing Compounds for the Building Industry
AS 1562.1	Design and Installation of Sheet Roof and Wall Cladding, Part 1: Metal
AS 2179	Specifications for Rainwater Goods, Accessories and Fasteners - Metal Shape or Sheet Rainwater Goods, and Metal Accessories and Fasteners
AS 2180	Metal Rainwater Goods - Selection and Installation
AS 2728	Prefinished/Prepainted Sheet Metal Products for Interior/Exterior Building Applications - Performance Requirements
AS 3566	Self-drilling Screws for the Building and Construction Industries

Scope

Where indicated on the drawings, provide and fix trapezoidal rib and pan roof and/or wall cladding as specified with all necessary fasteners, accessories, trims and flashings. All such work should be in accordance with AS 1562.1, AS 2179, AS2180 and AS 3566.

Materials

Roofing/Walling

Roofing/walling should be Trimclad® trapezoidal rib and pan roof/wall cladding as described below:

Number of Ribs	1 underlap, 1 overlap, 3 internal
Rib Height	29mm ± 1.0mm
Anti-Capillary Feature	Flute formed at junction of crest and flank of underlapping rib
Cover Width	762mm ± 4.0mm
Base Metal Thickness	0.42mm or 0.48mm
Approximate Total Coated Thickness	0.47mm or 0.53mm
Steel Base Description	AS 1397-G550 (550MPa minimum yield strength)
Metallic Coating Description	AS 1397-AZ 150 (150g/m ² minimum coating mass)
Organic Coatings (If Used)	To AS 2728
Normal Environments	COLORBOND® XRW steel
Severe Environments	COLORBOND® Ultra steel

*BMT means Base Metal Thickness

Fastener Selection for Non Cyclonic

	Fixing to Steel Batten Material 0.42mm to 1.0mm BMT	Fixing to Cold Formed Steel Purlin & Girt Material 1.2mm BMT to 3.5mm	Fixing to Hot Rolled Steel Purlin & Girt Material 3.5mm to 6.4mm (Non Stocked Items)	Fixing to Timber Supports Type 17	Number of Fasteners Approx per m ²
Crest Fixed	M6-11 x 50mm HiGrip® - Shankguard® Hex. Washer Hd. Self Drilling Roof Zips®	M5.5-14 x 50mm HiGrip® - Shankguard® Hex. Washer Hd. Self Drilling Auto Tek®	SHS 14-20 x 45mm Hex. Washer Hd. Self Drilling Screws	M6-11 x 65mm HiGrip® - Shankguard® Hex. Washer Hd. Self Drilling Roof Zips®	5 to 6
Valley Fixed	SHS 10-16 x 16mm Hex. Washer Hd. Self Drilling Screws	SHS 10-16 x 16mm Hex. Washer Hd. Self Drilling & Tapping Screws	SHS 14-20 x 22mm Hex. Washer Hd. Self Drilling & Tapping Screws	THS 12-11 x 25mm Hex. Washer Hd. Self Drilling Roof Zips®	5

Notes

1. Coating of fasteners should comply with AS 3566 Class 3 for exterior applications. XRW - Climaseal®, Ultra - ZAC® or 40 Micron Zinc, COLORBOND® Stainless Steel - Stainless Steel fasteners.
2. Add a minimum on 10mm to the nominated fastener length, when fixing over insulation blanket.
3. All fasteners exposed to the weather should be fitted with sealing washers to comply with ASTM, D 2000.
4. Any selection made from this table is to be checked against the latest version of BlueScope Steel Australia Technical Bulletin TB-16 to ensure that fastener finish is appropriate for the service conditions.

Workmanship

Care Storage & Handling

Packs of sheets should be kept dry in transit and on-site to prevent water and/or condensation being trapped between adjacent surfaces. Packs should be safely and neatly stacked on site, clear of the ground and protected from rain and moisture. Any sheets which become wet should be separated, wiped clean, dried and re-stacked in a manner to allow free air circulation.

Cutting

Sheets should be cut in a manner, and in a location, such that damage is avoided both to the sheets and to other nearby finished building products.





Installation

Sheets should be installed with correct overlaps on battens or purlins spaced at centres not exceeding the manufacturer's maximum recommended span for the specific conditions pertaining at the site of the works, as determined by the building designer. Wherever practicable roof runs should be covered with single-length sheets from crest to gutter. End laps and/or expansion joints should be provided in longer roofs at the spacings, and to the details, set down by the manufacturer's installation manual, and purlin/batten spacings and positions adjusted accordingly.

Sheets should be handled carefully, in the interests of Occupational Health and Safety (OHS) and to avoid damage to nearby finished building products. Where sheets and/or accessories are provided with stripable plastic coatings, this material should be removed at time of installation and disposed of in a responsible manner. Fix sheeting with appropriate fasteners in accordance with the instructions given in the manufacturer's installation manual.

Turn high ends of sheets up, and gutter ends down to the extent, and using the tool, specified in the manufacturer's installation manual. All flashings, trims and closures to adjoining work should be made from matching material, or from other approved compatible material and should be formed, notched and fitted so as to present an effective, neat and workmanlike finished job. Where necessary, flashings should be lapped and sealed at joints in accordance with the manufacturer's installation manual.

At the conclusion of each day's work, and at the completion of the roofing contract, all roof areas should be swept clean, ensuring that all metal swarf and other debris are removed. A close inspection should follow to make certain that no small, heavy items (e.g. unused fasteners or mandrels of concealed-fastening rivets) are lodged in places from which coating damage could be initiated.

QLD Roofing Warehouse

1 Rina Court, Varsity Lakes
Queensland 4220

P: 07 55 934766

F: 07 55 934860

E: info@roofingwarehouse.com.au

www.roofingwarehouse.com.au

All reasonable care has been taken in the compilation of the information contained in this brochure. All recommendations on the use of our products are made without guarantee as conditions of use are beyond the control of Metroll Pty Ltd. It is the customers responsibility to ensure that the product is fit for its intended purpose and that the actual conditions of use are suitable. Metroll Pty Ltd, pursues a policy of continuous development and reserves the right to amend specifications without prior notice. The Metroll M and Logo are registered trademarks of Metroll Pty Ltd.

AQUAPLATE®, COLORBOND®, GALVASPAN®, ZINCALUME® steels, Thermatech® are all registered trade marks of BlueScope Steel Limited.

Climaseal®, HiGrip®, Shankguard® and ZAC® are registered trade marks of ITW Buildex.